



## COMMERCIAL PRODUCT GUIDE



*Handcrafted for life*

[www.shawsofdarwen.com](http://www.shawsofdarwen.com)

## Product Features

All of our products feature a 10 year warranty against fading and staining and 1 year against manufacturing defects as standard.



### HEAT-PROOF

Shaws sinks will resist the hottest pots and pans and a quick clean will remove any traces of heat marks.



### IMPACT RESISTANT

Each sink is produced using heavy fireclay material; cast and glazed by hand, ensuring the products are resilient to cracking, chipping, however heavy-duty their usage.



### ODOUR RESISTANT

The surface of our glaze resists the trapping of food and other kitchen odours.



### CHEMICAL RESISTANT

Originally formulated for laboratories and hospitals, our unique glaze is guaranteed and certified as stainless and resistant to acids and alkalis.



### NATURAL MATERIAL

Shaws only uses virgin material which is completely recyclable.



### DIRT AND STAIN RESISTANCE

Fired at over 1200 degrees, our glaze becomes fused to the heavy fireclay, resulting in a very smooth and impermeable surface, making it very difficult for dirt and stains to become trapped.



### ANTIBACTERIAL

The hard-wearing glaze applied to every Shaws sink has been proven to reduce bacterial colonies of E-Coli and MRSA by 99.99% over a 24 hour period and is classified as Excellent in this area.



### RECYCLABLE

All waste is broken down and recycled, predominately used for chip board filler or base layers for new roads.

## SPECIFICATIONS FOR ALL INDUSTRIES

We know the importance of specifying the right products for your project. To help you choose the right model for you, we have created this guide. Look out for our icons throughout this brochure.



### EDUCATION

#### Schools | Colleges | Universities

High traffic environments such as schools require hard-wearing and robust products that can stand the test of time. Shaws sinks are resistant to stains and are extremely durable, making them ideal for heavy-duty use.



### HEALTHCARE

#### Hospitals | Care Homes

Shaws' unique Heavy Duty Fireclay material can help fight against infections and bacteria. Every sink is glazed to be chemical resistant and is proven to reduce bacterial colonies of E-Coli and MRSA by 99.99% over a 24 hour period.



### HOSPITALITY

#### Restaurants | Bars | Hotels

We know guests expect only the best. Hospitality staff need the right tools to deliver exceptional service. Shaws Cleaner sinks are designed for this market and will withstand heavy use every day. They are easy to clean and are odour, stain and impact resistant.



### PUBLIC PLACES

#### Retail | Transport | Museums

Washrooms in public buildings can face the most demanding usage. Visitors are not always careful, and washroom damage can be a major problem. Shaws sinks are manufactured primarily for durability. No one produces a stronger ceramic sink.



### RESIDENTIAL

#### Houses | Apartments

Whether a new development or refurbishment, residential properties require products which meet high expectations. The standard of kitchen and bathroom fittings reflect the quality of the development. A Shaws sink is recognised as a high-value, desirable and practical component, offering reassurance beyond the specifier to the homeowner.



### WORK ENVIRONMENTS

#### Offices

Businesses need peace of mind that workplace washrooms and kitchens are low maintenance whilst still being functional and appealing for their staff to use daily. A Shaws sink is manufactured to last, and will resist impact, dirt and stains – making it easy to care for, for as long as you need it.

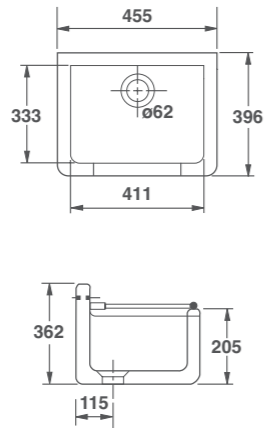

## 18" CLEANER

Width	Height	Depth
455mm	362mm	396mm

### Features

- > Acid and alkali resistant, antibacterial glazed surface.
- > Designed to withstand heavy use.
- > 1½" waste outlet.
- > Stainless steel bucket grating.
- > Pre-punched fixing holes.

**CL0300000**

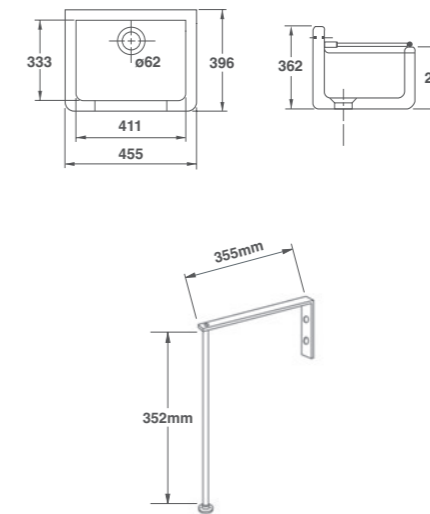

## 18" CLEANER SINK PACK

### Pack Contains

- > Fireclay Sink.
- > Legs & Brackets.
- > Lever/X Head Taps (WRAS Approved).
- > Wall Elbows.
- > Waste & Trap.

**CL03-PACK-A (LEVER)**  
**CL03-PACK-B (X HEAD)**

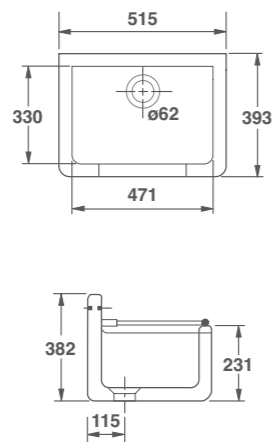

## 20" CLEANER

Width	Height	Depth
515mm	382mm	393mm

### Features

- > Acid and alkali resistant, antibacterial glazed surface.
- > Designed to withstand heavy use.
- > 1½" waste outlet.
- > Stainless steel bucket grating.
- > Pre-punched fixing holes.

**CL0200000**

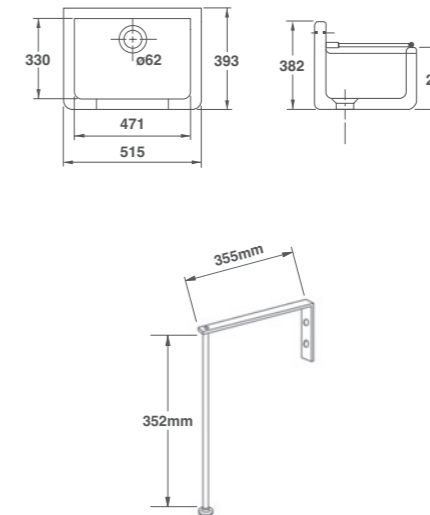

## 20" CLEANER SINK PACK

### Pack Contains

- > Fireclay Sink.
- > Legs & Brackets.
- > Lever/X Head Taps (WRAS Approved).
- > Wall Elbows.
- > Waste & Trap.

**CL02-PACK-A (LEVER)**  
**CL02-PACK-B (X HEAD)**

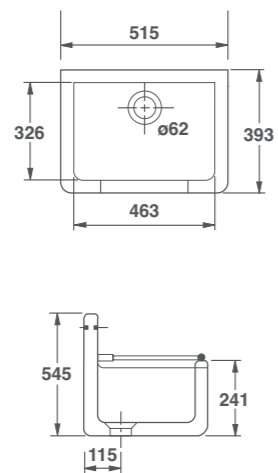

## 20" HIGH BACK CLEANER

Width	Height	Depth
515mm	545mm	393mm

### Features

- > Acid and alkali resistant, antibacterial glazed surface.
- > Designed to withstand heavy use.
- > 1½" waste outlet.
- > Stainless steel bucket grating.
- > Pre-punched fixing holes.

**CL0100000**

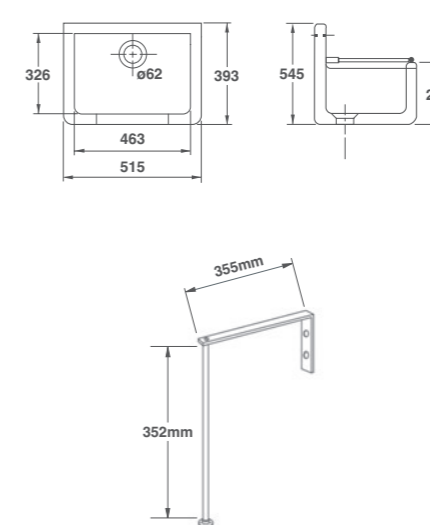

## 20" HIGH BACK CLEANER SINK PACK

### Pack Contains

- > Fireclay Sink.
- > Legs & Brackets.
- > Lever/X Head Taps (WRAS Approved).
- > Wall Elbows.
- > Waste & Trap.

**CL01-PACK-A (LEVER)**  
**CL01-PACK-B (X HEAD)**



## TRADITIONAL HEAVY DUTY FIRECLAY BELFAST SINK

### Features

- > Acid and alkali resistant, antibacterial glazed surface.
- > Designed to withstand heavy use.
- > Weir overflow.
- > 1½" centre end waste outlet.

### Recommended Accessories



Vulcathene Waste (Slotted)  
1½", 85mm flange  
FT8000003



Vulcathene Bottle Trap  
1½"  
FT8000001

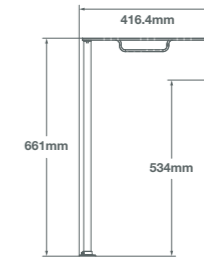

25" Stainless Steel  
Legs & Brackets (x2)  
FT0100002

## 18" BELFAST

Width	Height	Depth
460mm	205mm	380mm

**BS0100010**

## METRIC 24 BELFAST

Width	Height	Depth
595mm	245mm	455mm

**BS0800010**

## 30" BELFAST

Width	Height	Depth
795mm	245mm	460mm

**BS0600010**

## 36" BELFAST

Width	Height	Depth
895mm	245mm	460mm

**BS0700010**

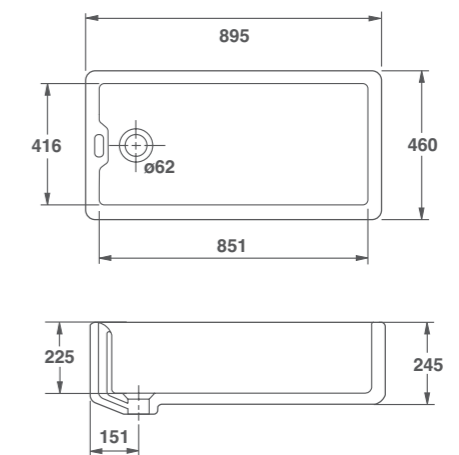
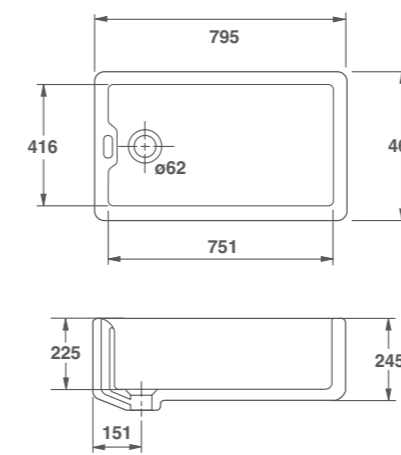
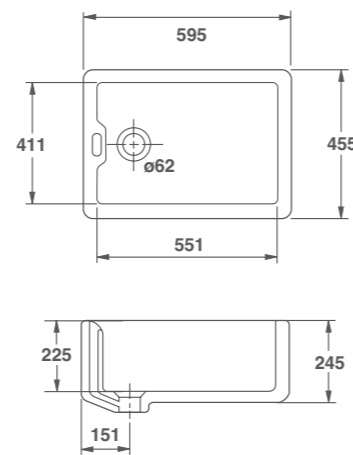
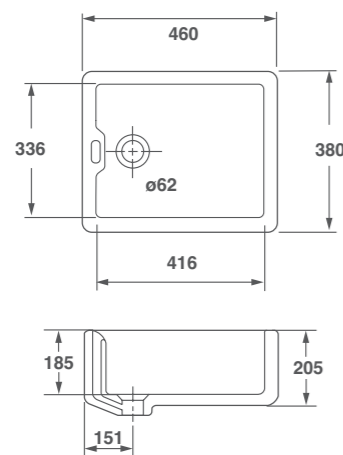



## EXTREMELY DURABLE, SCIENCE-FRIENDLY FIRECLAY LAB SINKS

### Features

- > Acid and alkali resistant, antibacterial glazed surface.
- > Designed to withstand heavy use.
- > Inset or undermount installation.
- > No overflow.
- > 1½" waste outlet.



### Recommended Accessories



Vulcathene Waste (Unslotted)  
1½", 73mm flange  
FT8000002



Vulcathene Bottle Trap  
1½"  
FT8000001

### LABORATORY TYPE 1

Width	Height	Depth
360mm	178mm	280mm

LB0100010

### LABORATORY TYPE 2

Width	Height	Depth
330mm	180mm	330mm

LB0200010

### LABORATORY TYPE 3

Width	Height	Depth
595mm	230mm	380mm

LB0400010

### LABORATORY TYPE 4

Width	Height	Depth
460mm	200mm	365mm

LB0300010

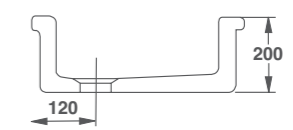
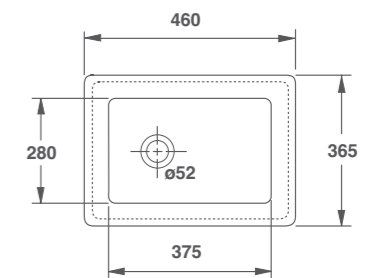
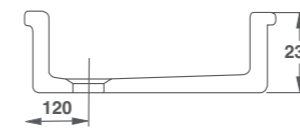
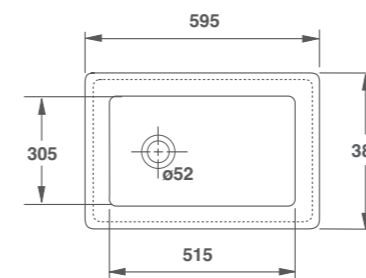
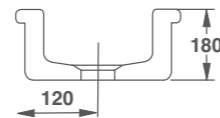
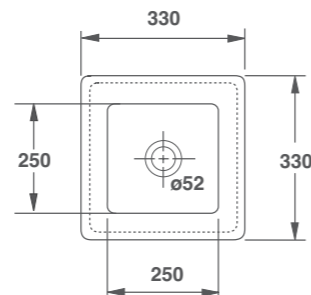
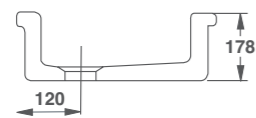
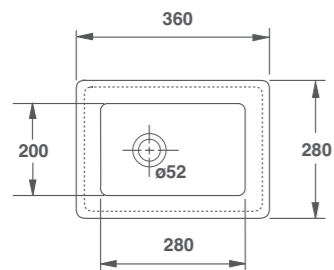





## 1 1/2" VULCATHENE WASTE

### Features

Part of the purpose-designed Vulcathene plumbing system, our Wastes are chemical resistant and have been created for heavy commercial use.

**FT8000003** (SLOTTED)  
**FT8000002** (UNSLOTTED)



## VULCATHENE BOTTLE TRAP

### Features

Specified and installed in commercial settings worldwide for over 60 years, Vulcathene is a completely purpose-designed chemical resistant plumbing system. Our Bottle Traps are built to withstand the test of time, in the most demanding of applications.

**FT8000001**

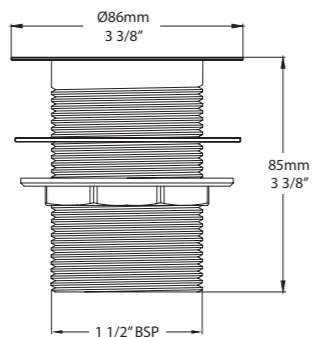

## 1 1/2" FLUSH GRATED WASTE

### Features

High quality flush grated waste, suitable for applications where plugs are not required.

> Chrome plated.

**FT1600013**

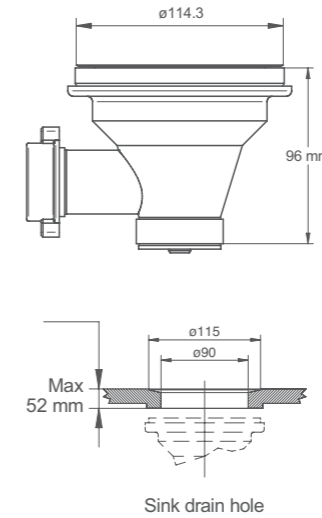

## 3 1/2" STRAINER WASTE

### Features

High quality basket strainer waste with overflow outlet.

> Chrome plated.

**FT2900056**

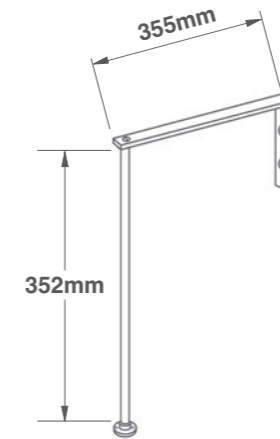

## CLEANER LEGS & BRACKETS x2

### Features

Designed to withstand heavy fireclay sinks, our stainless steel legs and brackets are tailored to floor-mount our Cleaner range.

> ø22mm stainless steel tube.

**FT0100001**

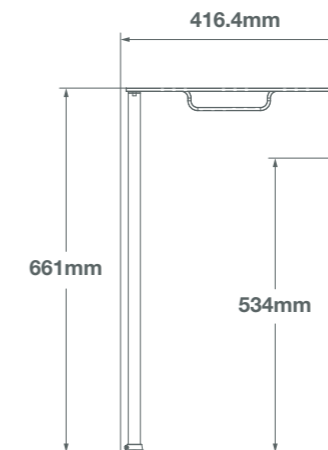

## BELFAST LEGS & BRACKETS x2

### Features

Designed to floor-mount our Belfast range, our legs and brackets are made from stainless steel to withstand heavy fireclay sinks.

> ø22mm stainless steel tube.

**FT0100002**



Both products are compatible with all the sink sizes in their respective range and are supplied with fixtures and fittings.







# COMMERCIAL PRODUCT RANGE

CLEANER	Code	Dimensions (mm)
18"	CL0300000	W: 455 H: 362 D: 396
20"	CL0200000	W: 515 H: 382 D: 393
20" High Back	CL0100000	W: 515 H: 545 D: 393
18" Cleaner Pack (Lever)	CL03-PACK-A	See 18" Cleaner / Cleaner Legs & Brackets
18" Cleaner Pack (X Head)	CL03-PACK-B	See 18" Cleaner / Cleaner Legs & Brackets
20" Cleaner Pack (Lever)	CL02-PACK-A	See 20" Cleaner / Cleaner Legs & Brackets
20" Cleaner Pack (X Head)	CL02-PACK-B	See 20" Cleaner / Cleaner Legs & Brackets
20" High Back Cleaner Pack (Lever)	CL01-PACK-A	See 20" High Back Cleaner / Cleaner Legs & Brackets
20" High Back Cleaner Pack (X Head)	CL01-PACK-B	See 20" High Back Cleaner / Cleaner Legs & Brackets

BELFAST	Code	Dimensions (mm)
18"	BS0100010	W: 460 H: 205 D: 380
Metric 24"	BS0800010	W: 595 H: 245 D: 455
30"	BS0600010	W: 795 H: 245 D: 460
36"	BS0700010	W: 895 H: 245 D: 460

LABORATORY	Code	Dimensions (mm)
Type 1	LB0100010	W: 360 H: 178 D: 280
Type 2	LB0200010	W: 330 H: 180 D: 330
Type 3	LB0400010	W: 595 H: 230 D: 380
Type 4	LB0300010	W: 460 H: 200 D: 365

WASTES & TRAPS	Code	Dimensions (mm)
1½" Vulcathene Waste (Slotted)	FT8000003	38 x 85 x 102
1½" Vulcathene Waste (Unslotted)	FT8000002	38 x 85 x 102
Vulcathene Bottle Trap	FT8000001	38
1½" Flush Grated Waste	FT1600013	38
3½" Strainer Waste	FT2900056	115

LEGS & BRACKETS	Code	Dimensions (mm)
Cleaner Legs & Brackets (x2)	FT0100001	Bracket length: 355 Leg length: 352 Leg diameter: 22
Belfast Legs & Brackets (x2)	FT0100002	Bracket length: 416.4 Leg length: 661 Leg diameter: 22

